

CHITA

THE RHYTHM OF MY LIFE

CHITA RIVERA SELF-CONTAINED RIDER

ATTACHED RIDER IS HEREBY MADE PART OF THE AGREEMENT DATED _____ BETWEEN **CHITA RIVERA** (Hereinafter referred to as "**ARTIST**" and _____ (Hereinafter referred to as "**PURCHASER**".)

BILLING: ARTIST is to receive 100% top sole Star billing.

STAGE REQUIREMENTS: Working stage to be no less than 24ft.x 24ft.

INSTRUMENTATION: Self Contained

ACCOMMODATIONS: PURCHASER to provide and pay for one (1) suite for Ms. Rivera and six (6) standard rooms for her entourage at a first class hotel for duration of engagement.

Artist and Co always arrive the day prior to performance unless otherwise indicated.

AIR TRANSPORTATION: PURCHASER to provide and pay for Seven (7) round trip airfares:
Two (2) first class round trip airfares
Five (5) -economy classes round trip airfares

Rosie Bentinck can be contacted for any information regarding ARTIST'S flights at 917-767-2786.

STAGEHANDS: PURCHASER to provide and pay for the following stagehands:

- Two (2) Spotlight Operators
- One (1) Lighting Console Operator/Programmer
- One (1) Audio Engineer

BACKLINE:

*PURCHASER to provide and pay for a piano tuned to standard A440 pitch on the first day of performance prior to set up and rehearsal, and said piano shall be kept in tune for the duration of rehearsal and engagement

*PURCHASER to provide and pay for one (1) drum set *PURCHASER to provide and pay for percussion toys as required by Artist.

*PURCHASER to provide and pay for one (1) upright acoustic bass.

*PURCHASER to provide and pay for one (1) Acoustic/Electric Guitar, Taylor NS72ce Nylon-String.

REHEARSAL: If symphony or 11-piece date we will need a 4-5 Hour Rehearsal one day prior to the concert.

On the day of the show we will need a 3-4 hour rehearsal with the orchestra which needs to finish 2 hours before show time. Chita will take part in the last hour of rehearsal.

If a Trio date we will only need a 2 hour rehearsal/sound check the day of the show to finish 2 hours before show time.

four 4

SOUND REQUIREMENTS: Purchaser to provide and pay for ~~two (2)~~ wireless hand-held microphones on stands with slip swivel holders. This does not include normal requirements for the orchestra. (6) six music stands with lights.

SOUND & LIGHTING: PURCHASER agrees to furnish a light and sound plot upon execution of this agreement showing specifically the lighting and sound facilities and personnel that will be available for this engagement.

GROUND TRANSPORTATION: PURCHASER to provide and pay for ground transportation as follows: Car service (1 Sedan or Limo and 1 Van) to be paid by PRESENTER and include all charges, tolls and gratuity.

The above cars to provide the following:

- From airport to hotel, and hotel to airport.
- To and from the theatre for rehearsal and shows.
- 1 car early on day 1 to take the lighting designer to the theatre from the hotel

In addition, one (1) car is to be provided for ARTIST'S disposal during the engagement.

Armando del Rivero can be contacted for any information regarding ARTIST'S arrival and departure schedule at 860-891-8254.

One stool (black) on stage

DRUM SET:

Purchaser agrees to furnish and pay for. Four piece Yamaha drum set -

Yamaha Maple Custom Absolute with the following sizes: -

20" kick, 14" snare, 12" rack tom, 14" floor Tom

- All drums should be jazz/shallow depths. NO power or deep toms

- Cymbals should be Dark k Zildjian JAZZ Cymbals. Ride, 2 crash, hi hats

All drums should be jazz/shallow depths. NO power or deep toms.

Zildjian K jazz dark cymbals. Ride, 2 crash, hi hats

Glockenspiel (orchestra bell)

Shaker

Guitar direct box

Claves

UPRIGHT ACOUSTIC BASS:

Purchaser agrees to furnish and pay for.

The Upright bass must be a 3/4 Size instrument (standard size) and of the highest professional quality. It will be equipped with the David Gage Bass Pickup (this is the standard for professional basses). A skilled String Bass Luthier will have examined and set the bass up correctly for use in jazz music, though it must also work with a bow. The bass must have been examined and maintained by a skilled string bass luthier within the last year.

Purchaser will supply a German Bass Bow for use in performance. (A French bass bow will not be acceptable)

Purchaser will supply a quality bass amp with a 15 inch speaker with at least 100 watts of power.

Examples will be a Polytone Minibrute with a 15 inch speaker or other similar brands such as Gallien Kruger, SWR, etc.

ACOUSTIC/ELECTRIC GUITAR:

Taylor NS72ce

Nylon-String

Follow link for description:

<http://www.taylorguitars.com/Guitars/AcousticElectric/Ny10n/NS72ce/>

CATERING/HOSPITALITY REQUIREMENTS

DRESSING ROOM

IF WE CAN MAKE SURE THERE IS ENOUGH LIGHT AROUND THE MAKEUP MIRROR, AND ALSO THAT THE CHAIR IS HIGH ENOUGH TO SEE INTO THE MIRROR.

Clothes steamer

Iron and ironing board

2 large and 4 small Towels

8 Coat Hangers and 4 Clip Hangers

Box Kleenex

Hot Water Kettle

2 mugs

2 teaspoons

water glasses, and 1 needed on stage.

herbal tea bags (red zinger, passion, mint, throat coat)

sweet and low

equal

bottles of cold and room temperature water, for Chita, musicians, and group, in dressing rooms and on stage for rehearsal

4 bottles needed on stage per show

BACK STAGE

tea and coffee

Orange juice, Cranberry Juice

soda, coke, sprite, diet coke, diet doctor pepper.

iced tea, diet and regular, (snapple is fine)

Food, lunch, sandwiches, and chips

we have 1 vegetarian who eats no meat or fish, but does eat eggs and cheese, chips low fat, and regular

cookies

Fruit

Dinner, served before each show.

Hot Food

Meat and Fish

Pasta

Vegetarian Option

Vegetables

Salad

Bread and Butter

Fruit

Dessert, Brownies, Cake, Cookies

For Chita:

Soup, Chicken Noodle, Chicken Rice or Vegetable, (Nothing with Cream)

Tuna or Chicken Salad

Crackers

FLIGHTS AND CATERING CONTACT:

Rosie Bentinck

Cell: 917-767-2786

Email: englishrosie8@aol.com

ARTIST MANAGER CONTACT:

Armando Del Rivero

Phone: 860-891-8254

Email: modesto20041@comcast.net

PURCHASER

CHITA PRODUCTIONS, LLC



CHITA RIVERA INPUT LIST

For 6 PIECE Configuration

Please address questions to Michael Croiter mecroiter@mac.com

INPUT	Microphones/DI/amp	Use for	FX INSERT	BACK LINE
1	Wireless Shure BETA58A	CHITA lead Vox	REV	PLEASE SEE ATTACHED TECH. RIDER
2	Shure SM58 or Sennheiser e9	DRUMMER vox	REV	NOTES:
3	"	PIANO vox	REV	
4	Wireless Shure BETA58A	Spare Vox	REV	
5	Audix D SERIES drum mics	Kick	REV	
6	"	Snare		
7	"	Hi Hat		
8	"	Rack tom		
9	"	Floor Tom 1		
10	"	Overhead Left		
11	"	Overhead Right		
12	D/I BOX	acoustic guitar	REV	
13	up to engineer	PIANO	none	
14	up to engineer	PIANO	none	
15	mic up to engineer	ACOUSTIC BASS	none	
16	D/I BOX	ACOUSTIC BASS	none	
17	mic up to engineer	REED 1 high	none	
18	mic up to engineer	REED 2 low	none	
19	mic up to engineer	Violin	none	
20	mic up to engineer	Trumpet	none	STAGE MONITORS
21	mic up to engineer	Glockenspiel	none	JBL JRX112M or similar
22				
23				
24				
25				
26				
27				
28				
29				
30				
31				



CHITA RIVERA INPUT LIST

For 11 PIECE Configuration

Please address questions to Michael Croiter mecroiter@mac.com

INPUT	Microphones/DI/amp	Use for	FX INSERT	BACK LINE
1	Wireless Shure BETA58A	CHITA lead Vox	REV	PLEASE SEE ATTACHED TECH. RIDER
2	Shure SM58 or Sennheiser e9	DRUMMER vox	REV	NOTES:
3	"	PIANO vox	REV	
4	Wireless Shure BETA58A	Spare Vox	REV	
5	Audix D SERIES drum mics	Kick	REV	
6	"	Snare		
7	"	Hi Hat		
8	"	Rack tom		
9	"	Floor Tom 1		
10	"	Overhead Left		
11	"	Overhead Right		
12	D/I BOX	acoustic guitar	REV	
13	up to engineer	PIANO	none	
14	up to engineer	PIANO	none	
15	mic up to engineer	ACOUSTIC BASS	none	
16	mic up to engineer*	ACOUSTIC BASS*	none	
17	mic up to engineer	REED 1 high	none	
18	mic up to engineer	REED 1 low	none	
19	mic up to engineer	REED 2 High	none	
20	mic up to engineer	REED 2 low	none	
21	mic up to engineer	VIOLIN	REV	
22	mic up to engineer	CELLO	REV	
23	mic up to engineer	TRUMPET 1	none	
24	mic up to engineer	TRUMPET 2	none	
25	mic up to engineer	TROMBONE	none	
26	mic up to engineer	PERC. Timpani	none	
27	mic up to engineer	PERC, toys	none	
28	mic up to engineer	PERC, congas	REV	
29	mic up to engineer	PERC. Vibes	none	
30	mic up to engineer	PERC. Xylo/Glock	none	
31	mic up to engineer	PERC. Bongos	REV	

* 2 bass mics needed.

STAGE MONITORS

JBL JRX112M or similar

TRIO CONFIGURATION

FULLSTAGE BLACK

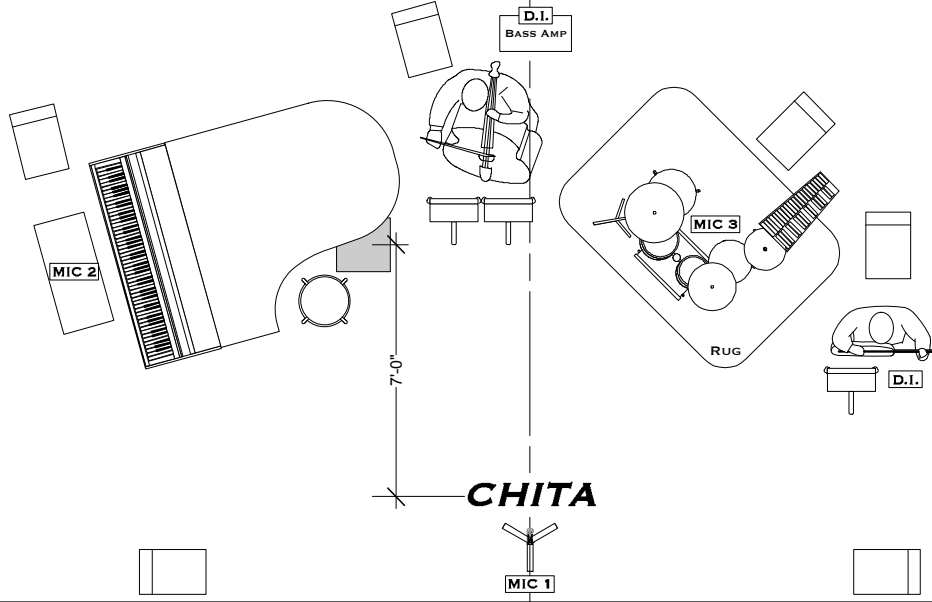

4-PIECE CONFIGURATION

FULLSTAGE BLACK

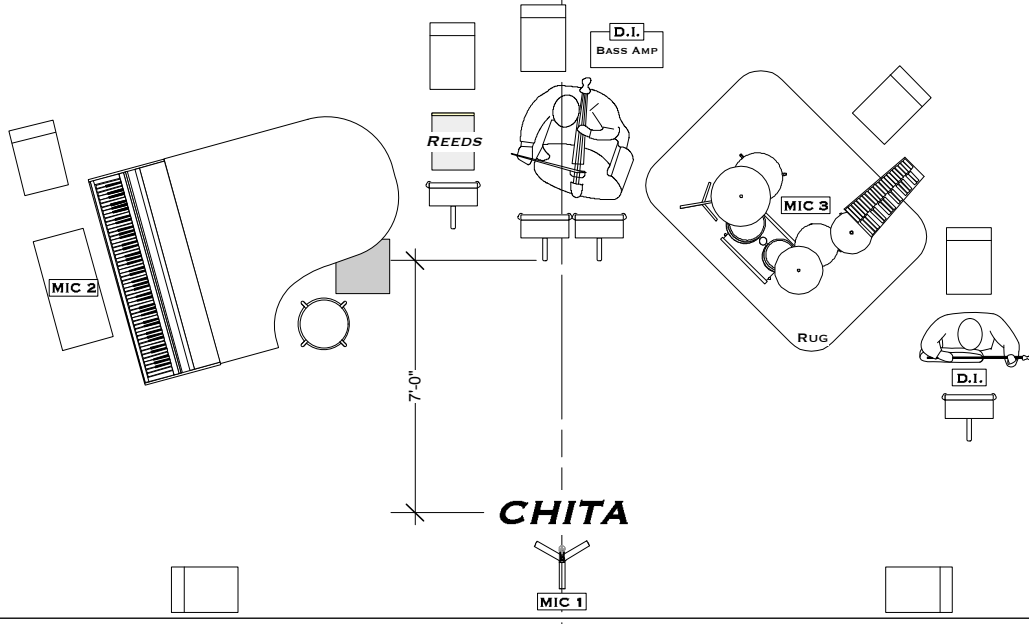

SCALE: 3/16" = 1'-0"

DATE: 2014-02-27

CHITA RIVERA: A LEGENDARY CELEBRATION - STAGE LAYOUT

NOTES:

1. SEE TECH. RIDER FOR INSTRUMENT SPECIFICS.
2. ALL MICS ARE VOCAL MICS.
3. CHITA'S MIC IS A ROUND-BASE SCREW-TELESCOPING MIC STAND W/ WIRELESS HANDHELD.
4. PLATFORM DIMENSIONS AS NOTED.

5. PIANO STAND LIGHT SHOULD BE A LEKO FROM AN ELECTRIC DIRECTLY ABOVE PIANO.
6. STAND LIGHTS ARE ON DIMMABLE POWER.
7. IN TRIO AND QUARTET CONFIGURATIONS, DRUMMER ALSO PLAYS PERCUSSION AND GUITAR.
8. PROVIDE 18"x18"x18" BLACK BOX FOR PROPS.

KEY:

- MUSIC STAND W/ CLIP LIGHT
- MONITOR
- BLACK WOODEN STOOL
- BLACK CHAIR
- BLACK BOX

6-PIECE CONFIGURATION

FULLSTAGE BLACK

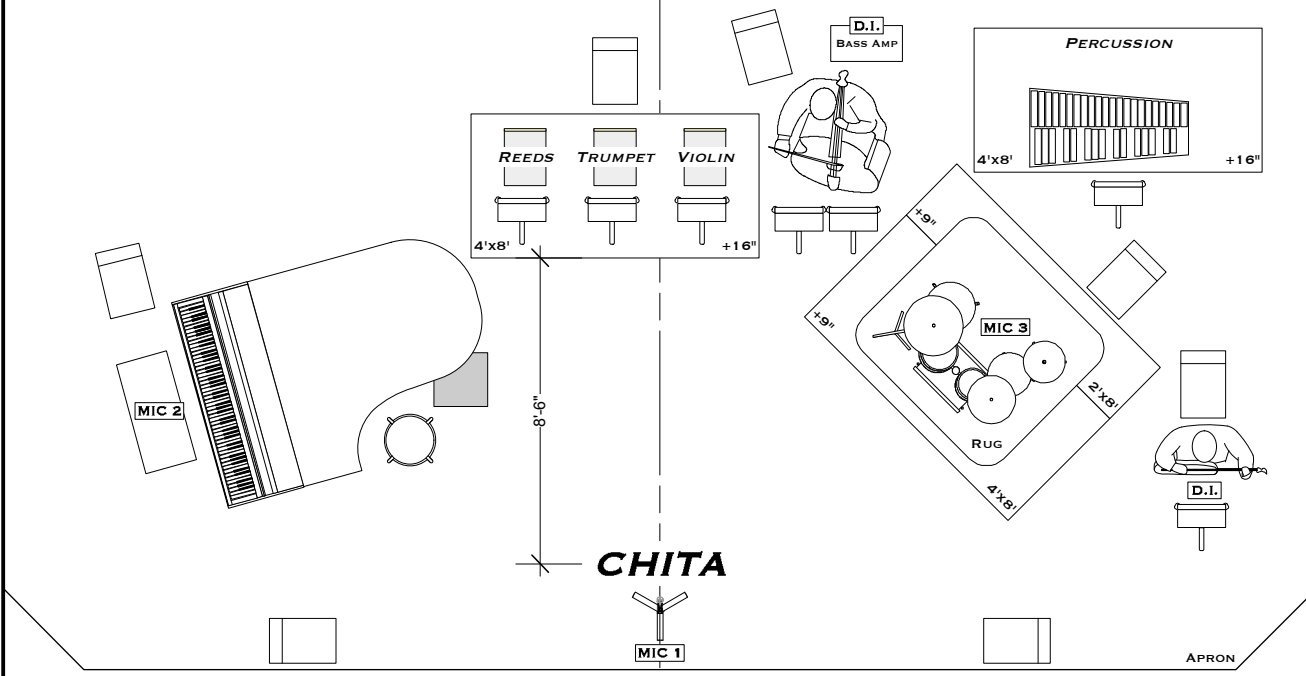

11-PIECE CONFIGURATION

FULLSTAGE BLACK

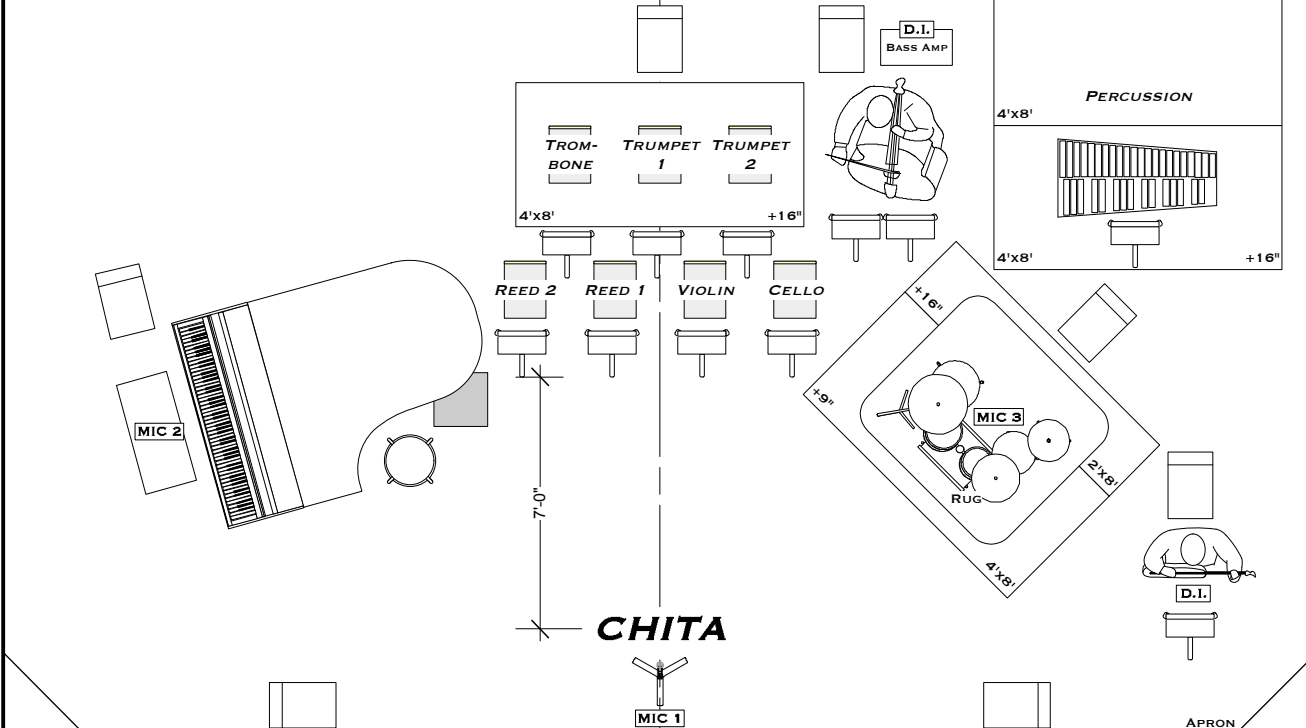

CHITA RIVERA: A LEGENDARY CELEBRATION - STAGE LAYOUT **DATE: 2014-02-27** **SCALE: 3/16" = 1'-0"**

NOTES:

1. SEE TECH. RIDER FOR INSTRUMENT SPECIFICS.
2. ALL MICS ARE VOCAL MICS.
3. CHITA'S MIC IS A ROUND-BASE SCREW-TELESCOPING MIC STAND W/ WIRELESS HANDHELD.
4. PLATFORM DIMENSIONS AS NOTED.

5. PIANO STAND LIGHT SHOULD BE A LEKO FROM AN ELECTRIC DIRECTLY ABOVE PIANO.
6. STAND LIGHTS ARE ON DIMMABLE POWER.
7. IN TRIO AND QUARTET CONFIGURATIONS, DRUMMER ALSO PLAYS PERCUSSION AND GUITAR.
8. PROVIDE 18"x18"x18" BLACK BOX FOR PROPS.

KEY:

- MUSIC STAND W/ CLIP LIGHT
- MONITOR
- BLACK WOODEN STOOL
- BLACK CHAIR
- BLACK BOX

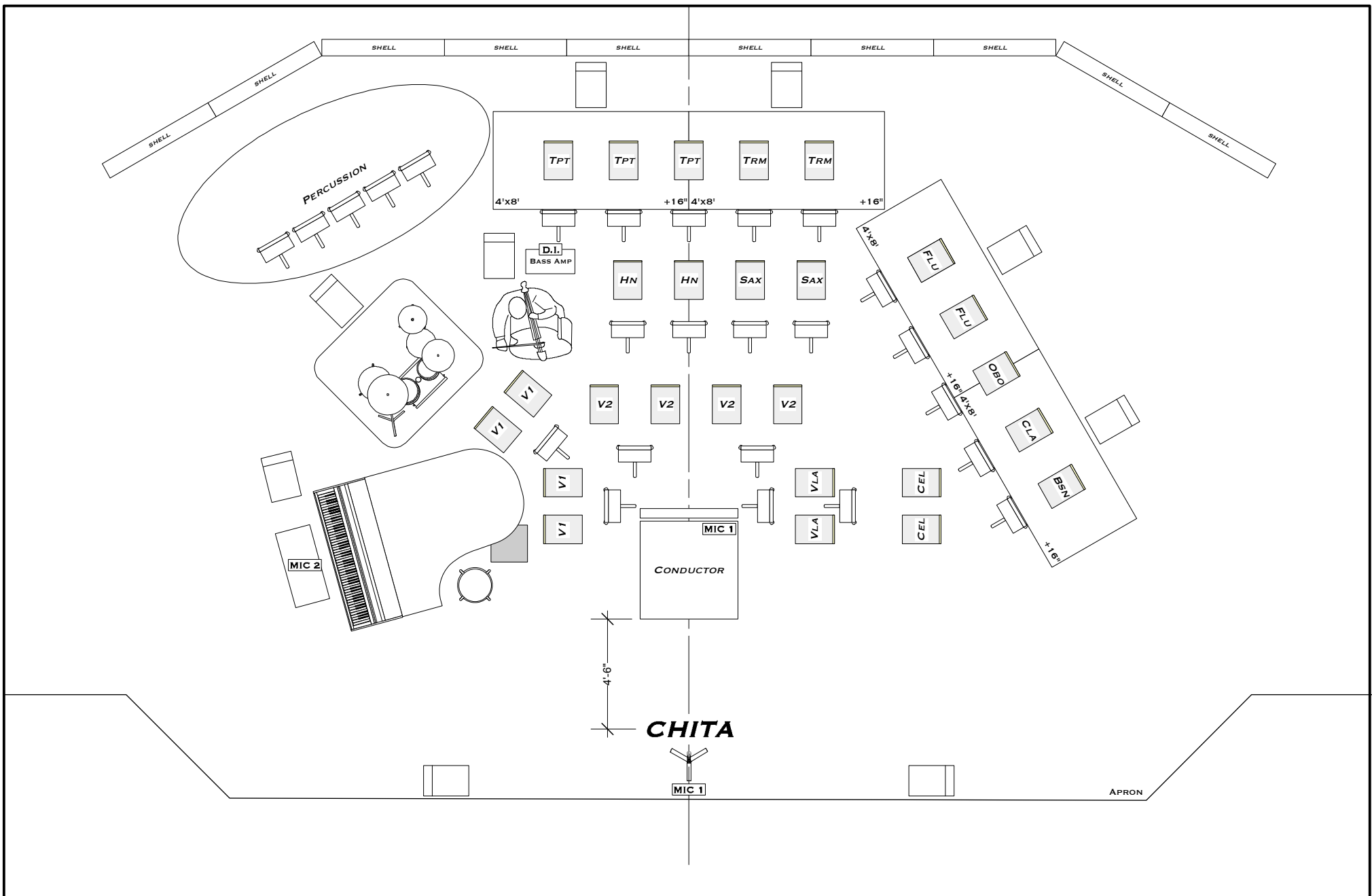

CHITA RIVERA: A LEGENDARY CELEBRATION – STAGE LAYOUT

DATE: 2014-02-27

SCALE: 3/16" = 1'-0"

KEY:

-  MUSIC STAND W/ CLIP LIGHT
-  MONITOR
-  BLACK WOODEN STOOL
-  BLACK CHAIR
-  BLACK BOX

NOTES:

1. SEE TECH. RIDER FOR INSTRUMENT SPECIFICS.
2. ALL MICS ARE VOCAL MICS.
3. CHITA'S MIC IS A ROUND-BASE SCREW-TELESCOPING MIC STAND W/ WIRELESS HANDHELD.
4. PLATFORM DIMENSIONS AS NOTED.

5. PIANO STAND LIGHT SHOULD BE A LEKO FROM AN ELECTRIC DIRECTLY ABOVE PIANO.
6. STAND LIGHTS ARE ON DIMMABLE POWER.
7. IN TRIO AND QUARTET CONFIGURATIONS, DRUMMER ALSO PLAYS PERCUSSION AND GUITAR.
8. PROVIDE 18"x18"x18" BLACK BOX FOR PROPS.